



# Mellott

## LOG AND LUMBER HANDLING SYSTEMS

### 15 TON TILT HOIST (New Style)



The Mellott 15 Ton Tilt Hoist is designed to unstack stickered packages of lumber. The standard machine is designed for 72" high x 96" wide x 16' long packages. Different columns and forks are available.

Very Heavy construction and a simple design are used throughout the 15 Ton Tilt Hoist in order to keep maintenance and down time to a minimum.



Optional conveyors include: Infeed decks, outfeed conveyors, stick removal conveyors and stick stacking systems. Combined, these conveyors make a reliable, heavy duty tilt hoist system.

### FEATURES

- The steel columns are welded to a 16" diameter pivot tube at the bottom and a 3" square tube at the top to tie all the columns together for extra strength
- Dual Lift cylinders are 5" bore, 3000 psi rated cushioned hydraulic cylinder with (2) heavy RC240 roller chains
- Lift cylinders are guarded to prevent damage to the cylinders and kiln sticks
- Two heavy leaf chains used in a "x" arrangement for load leveling
- Tilt cylinders are two 5" bore, 3000 psi rated cushioned hydraulic cylinders
- Chain attachments use standard connecting links
- Cylinder arms are 2" thick flame cut arms that completely wrap the pivot tube
- Steel rollers used in all of the forks in order to distribute the load to all of the columns

### MELLOTT MFG. CO., INC.

13156 Long Lane  
Mercersburg, PA 17236  
Phone: (717) 369-3125 Fax: (717) 369-2800  
sales@mellottmfg.com

[www.mellottmfg.com](http://www.mellottmfg.com)



# LOG AND LUMBER HANDLING SYSTEMS

## 15 TON TILT HOIST

### SPECIFICATIONS

Base Frame .....	S12 X 31.8 Beam
Pivot Bearings .....	Blue Brute Spherical 3 7/16"
Pivot Tube.....	16" Diameter Pipe
Columns.....	10" x 3" x 1/4" wall tubing
Forks .....	8" x 4" x 1/4" wall tubing
Tilt Cylinders.....	(2) 5" bore X 30" stroke, 3000 psi rated cushioned hydraulic cylinders
Lift Cylinders.....	(2) 5" bore X 39" stroke, 3000 psi rated cushioned hydraulic cylinders
Lift Chain.....	240-XDO roller chain
Leveling chain .....	BL1423 leaf chain
Tilt Angle .....	45 degrees
Fork Spacing 3 arm .....	72", 72"
4 arm .....	54", 36", 54"
5 arm .....	24", 24", 36", 60"
Package Size .....	72" high x 96" wide x 18' Maximum
Package Weight .....	15 ton maximum
Hydraulic requirements.....	34 Gpm, pressure compensated @ 2000 psi
Overall Weight (5 Arm Model) .....	18,500 Lbs

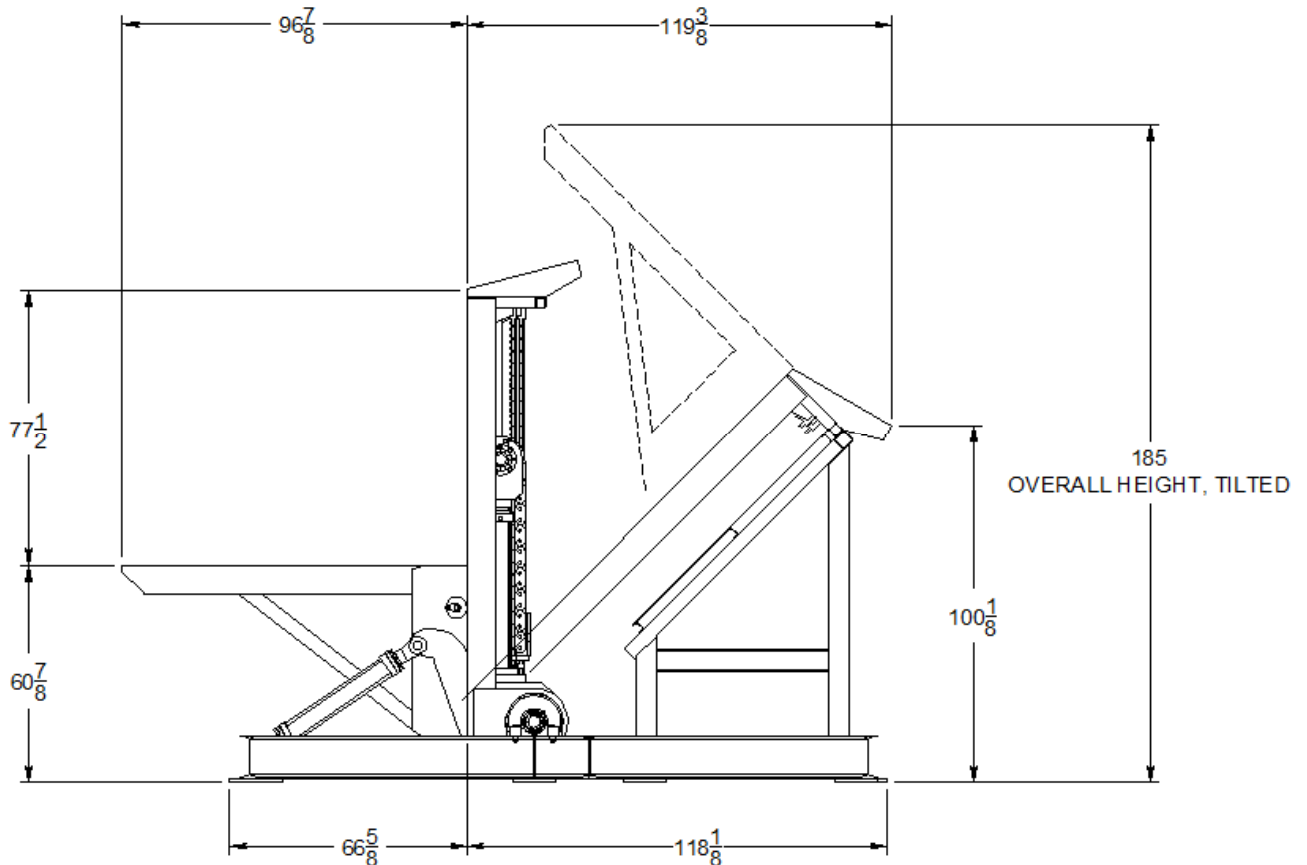

**MELLOTT MFG. CO., INC.**

13156 Long Lane  
 Mercersburg, PA 17236  
 Phone: (717) 369-3125 Fax: (717) 369-2800  
 sales@mellottmfg.com

[www.mellottmfg.com](http://www.mellottmfg.com)