



Mellott

LOG AND LUMBER HANDLING SYSTEMS

MODEL 640 - 6' BANDSAW

FEATURES

- Cast top wheel with oversized bearings and shafts
- Round ways for the top guide with no lube bearings. No more adjusting gibes, oiling or replacing wear strips
- Oversized jacks for raising the top wheel
- 8" diameter nitrided support tubes
- Top wheel scraper tilts and moves up and down with the top wheel. It's always in the correct position. Our scraper blades are straight so you can reverse them when one side wears out
- Extra heavy frame and columns



FEATURES

- Lower wheel uses rail car bearings, Bearing housings are keyed and bolted
- All alignment adjustments are made at the top wheel
- Bolts to adjust level and bolt the machine down are on an exterior gusseted frame are easy to access and use
- Easy access lower guide adjusting bolts, are adjusted from the front of the guide



MELLOTT MFG. CO., INC

13156 Long Lane
Mercersburg, PA 17236
Phone: (717) 369-3125 Fax: (717) 369-2800
sales@mellottmfg.com

www.mellottmfg.com



LOG AND LUMBER HANDLING SYSTEMS

MODEL 640 - 6' BANDSAW

SPECIFICATIONS

BANDSAW BLADES:	12" X 40'
BASE AND COLUMNS:	HEAVY DUTY BASE AND COLUMNS, COMBINED WEIGHT IS 10,000 LB.
UPPER WHEEL:	72" DIAMETER CAST DUCTILE IRON WITH SPHERICAL BEARINGS
LOWER WHEEL:	72" DIAMETER CAST DUCTILE IRON WITH TIMKEN AP RAILCAR BEARINGS
UPPER WHEEL GUIDES:	8" DIAMETER SBN (SALT BATH NITRIDED) TREATED GUIDES
UPPER WHEEL LIFT:	(2) 10 TON WORM SCREW JACKS, HYDRAULICALLY DRIVEN
UPPER WHEEL TILT:	(1) 10 TON WORM SCREW JACK WITH ¾ HP ELECTRIC DRIVE
STRAIN:	ECCENTRIC TYPE AIR TENSION WITH SAFETY SPRING
SAW GUIDES:	CARTRIDGE TYPE UPPER AND LOWER PRESSURE GUIDES
WHEEL GUARD:	PIVOTING UPPER WHEEL GUARD, HYDRAULIC OPERATED
UPPER GUIDE TRAVEL	HARDENED ROUND WAYS
UPPER GUIDE CONTROL	MANUAL WITH HYDRAULIC CYLINDER
ASSEMBLED WEIGHT:	24,500 LB.

INCLUDES AIR FILTERING AND PRESSURE CONTROL SYSTEM FOR STRAIN
INCLUDES ALL HYDRAULIC VALVES, FLOW CONTROLS, ETC FOR SAW FUNCTIONS
INCLUDES PUSHBUTTONS, SWITCHES, ETC. FOR LIFT, TILT AND SHIELD
INCLUDES GUIDE BLOCK DRESSING MACHINE

DOES NOT INCLUDE MOTOR STARTERS



Heavy Duty Offbearer constructed of:

- 3/4" flame cut plate
- 8" diameter heavy wall machined pulleys with 1 15/16" shafts

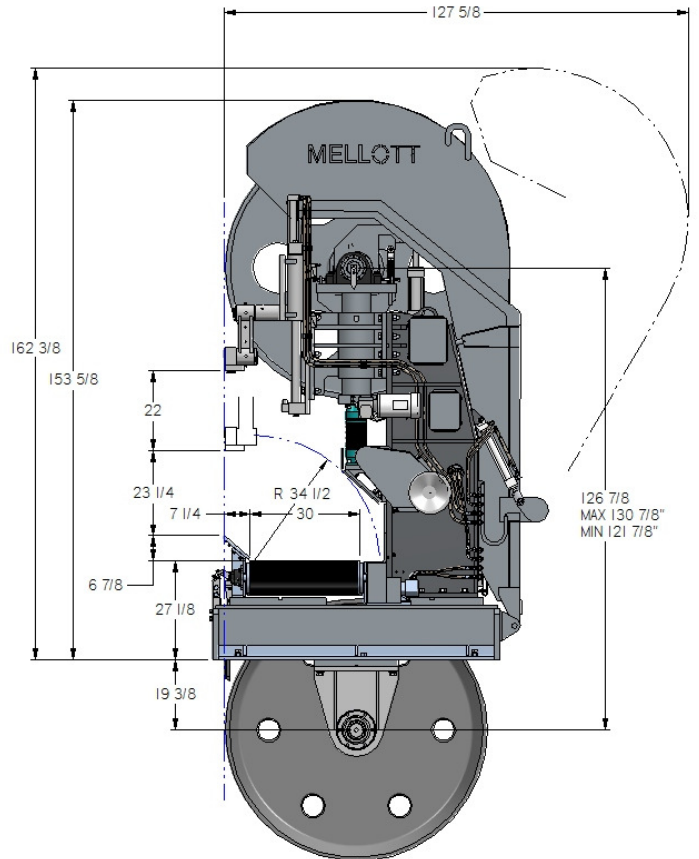

MELLOTT MFG. CO., INC

13156 Long Lane
Mercersburg, PA 17236
Phone: (717) 369-3125 Fax: (717) 369-2800
sales@mellottmfg.com

www.mellottmfg.com