

SAFETY

**NOTE: SAFETY ON AND AROUND THE DEBARKER
DEPENDS GREATLY UPON THE OPERATOR.**

1. DO NOT PERMIT PERSONNEL TO STAND NEAR DEBARKER DURING DEBARKING OPERATION OR WHILE DEBARKER IS RUNNING.
2. SHUT OFF POWER AND DISCONNECT PRIOR TO BEGINNING ANY MAINTENANCE ON DEBARKER.
3. DO NOT LEAVE CONTROL PLATFORM UNTIL POWER IS SHUT OFF.
4. FOLLOW RECOMMENDED MAINTENANCE PROCEDURES AND LUBRICATION CHARTS SO THAT PROPER SERVICE LEVEL CAN BE MAINTAINED.
5. DO NOT EXCEED LISTED AIR AND HYDRAULIC PRESSURE SETTINGS.
6. UTILIZE QUALIFIED ELECTRICIAN FOR INSTALLATION AND SERVICE OF ELECTRIC CIRCUITS.
7. DO NOT OPERATE DEBARKER WITHOUT SHIELDS AND GUARDS IN PLACE.
8. ALWAYS OBSERVE SAFETY LABELS

INSTALLATION

DEBARKER INSTALLATION

- ◆ Check for damage to hoses, wiring, cylinders, etc., that may have occurred during shipment.
- ◆ Before installation and start up, go over entire machine and check for loose bolts, fittings, etc.
- ◆ Debarker should be installed on foundation as shown on installation drawing.

Electrical:

- Debarker is pre-wired at factory.
- The motor wires are connected to starters at the factory.
- Connect the disconnect switch to proper voltage and check to see that motors rotate in the correct direction.
- Wiring should be routed through the floor of operator's platform.

CAUTION: BE CERTAIN THAT WIRING TO MACHINE IS HEAVY ENOUGH TO CARRY AMPERAGE REQUIRED.

Air:

- Connect air supply to filter-regulator-lubricator mounted under operator's platform.
- Air pressure is pre-set at factory (125 psi).
- For normal operation a 5 hp compressor or 38 cubic feet per minute of compressed air is required.

Hydraulics:

- All hydraulic connections for debarker are made at the factory. The tank is filled with hydraulic oil and unit has been tested at factory.
- Before operation, check for loose connections or hoses that may have been frayed or broken during shipment.

CAUTION: SHUT-OFF VALVE LOCATED AT THE RETURN SIDE OF HYDRAULIC TANK MUST BE IN THE OPEN POSITION BEFORE HYDRAULIC PUMP IS STARTED.

Infeed Deck:

- Optional infeed deck should be installed as shown on installation drawing.
- Make hydraulic connections to the hydraulic control valve marked Live Deck and Stop and Loader, mounted on the control stand as shown on the hydraulic circuit diagram for Live Deck.
- Hoses should be routed through floor of the operator's platform.

OPERATION

ELECTRICAL SYSTEM

CAUTION: UTILIZE QUALIFIED ELECTRICIAN FOR ALL ELECTRICAL MAINTENANCE.

The electrical system consists of the following components plus wiring. (See electrical schematic).

1. Electrical enclosure mounted on operator's platform contains motor starters, push buttons, fuses and transformer.
 2. Log Kickoff Control System:
 - A. Push button switch mounted on control stand.
 - B. Solenoid operated air valve (also described under air system).
 - C. Proximity Switch installed in base end of head control cylinder, which prevents kickoff from being actuated unless the head is in the "up" or raised position.
 3. Thirty (60) HP, 1800 rpm electric motor mounted on the carriage which powers the cutterhead.
 4. Fifteen (20) HP, 1800 rpm electric motor mounted under operator platform which powers the hydraulic pump.
-

OPERATION

AIR SYSTEM COMPONENTS

The air system consists of the following components plus hoses and fittings.(See figure 1)

1. **Filter-Regulator-Lubricator** located under operator's platform, regulates the system pressure, lubricates and filters the air for the entire system. This regulator should be set for 100 psi.
 2. **Hand Operated Control Valve** mounted on the control stand controls the up and down movement of the head and the down pressure the head exerts on the log.
 3. **Head Control Air Cylinder** mounted on carriage raises and lowers the head.
 4. **Solenoid Operated Control Valve** located on the debarker below the operator's platform controls the log kickoff air cylinder. This valve is actuated by a pushbutton on the control stand. Two (2) exhaust restrictors are mounted to the valve exhaust ports and control the exhaust air and the speed of the cylinder.
 5. **Log Kickoff Air Cylinder** located within the frame operates the log kickoff arms and is controlled by the solenoid operated air valve.
 6. **CAUTION:** When air system is completely shut off, the hose from head control valve to rod end of head lift cylinder to check valve will still be energized. **ALL** air must be bled from the line before doing maintenance.
-

AIR SYSTEM
(MODEL 210-3)

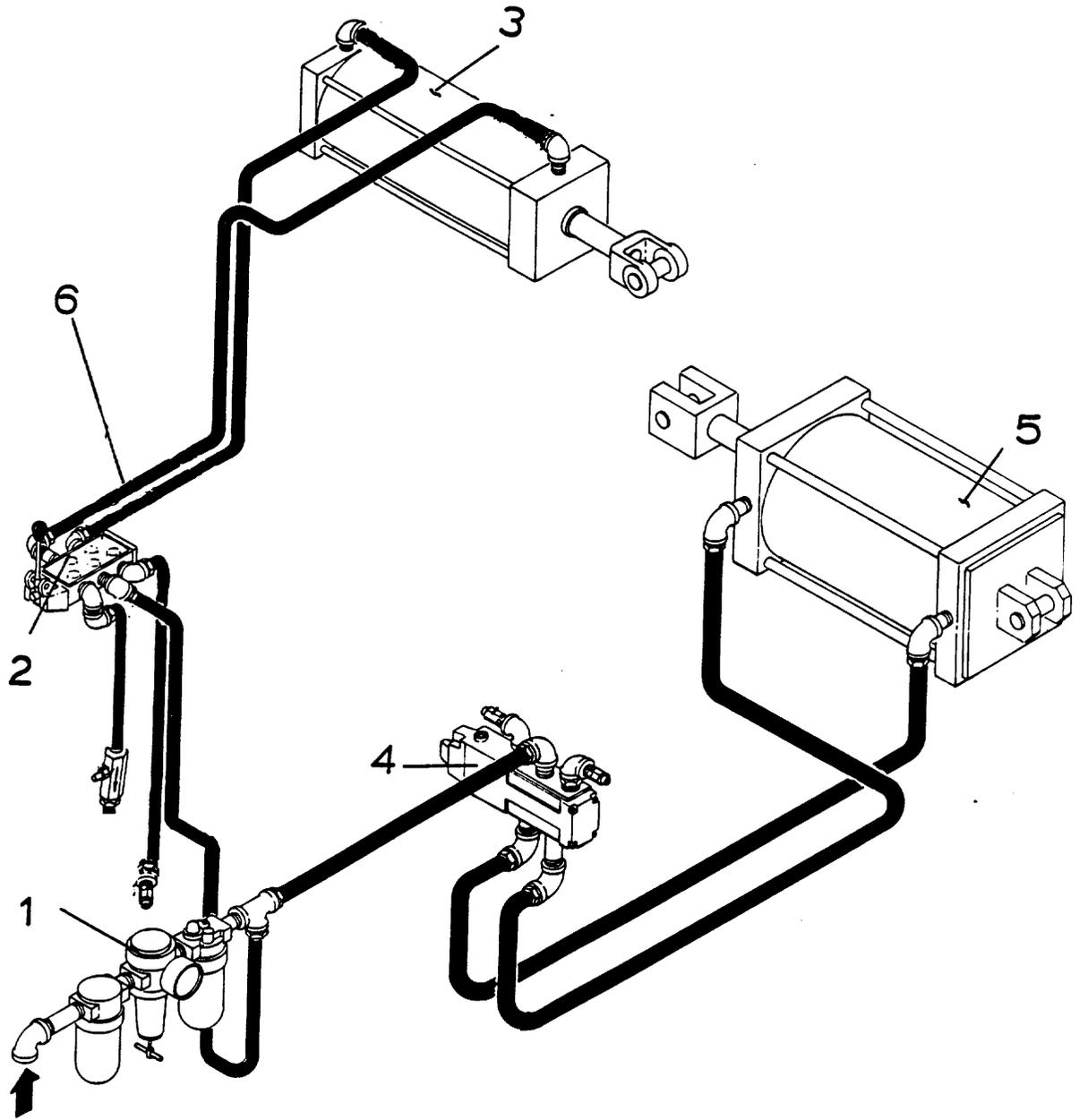

(FIGURE 1)

OPERATION

HYDRAULIC SYSTEM COMPONENTS

The hydraulic system consists of the following components plus hoses and fittings. (See Figure 2).

1. **Hydraulic Tank** located next to operator's platform. The tank is equipped with a breather on the top, and internal strainer on the suction side, a shut-off valve and cartridge filter on the return side. Capacity of this tank is 100 gallons.
 2. **Hydraulic Pump** located under the operator's platform is powered by a 20 hp electric motor. The pump is a 2 stage pump supplying both the log rotation and carriage drive motors.
 3. **Log Rotation Control Valve** mounted on the control stand controls the speed and direction of rotation of the bullwheels.
 4. **Carriage Drive Control Valve** mounted on the control stand controls the direction of travel of the carriage.
 5. **Live Deck Control Valve** mounted on the control stand controls the chains and stop and loader for the live deck feeding the debarker.
 6. **Log Rotation Hydraulic Motor** located within the debarker frame is controlled by the log rotation control valve and drives the bullwheels through a roller chain drive.
 7. **Carriage Drive Hydraulic Motor** located to the left and below the operator's platform is controlled by the carriage drive control valve and drives the carriage roller chain.
-

HYDRAULIC SYSTEM
(MODEL 210-3)

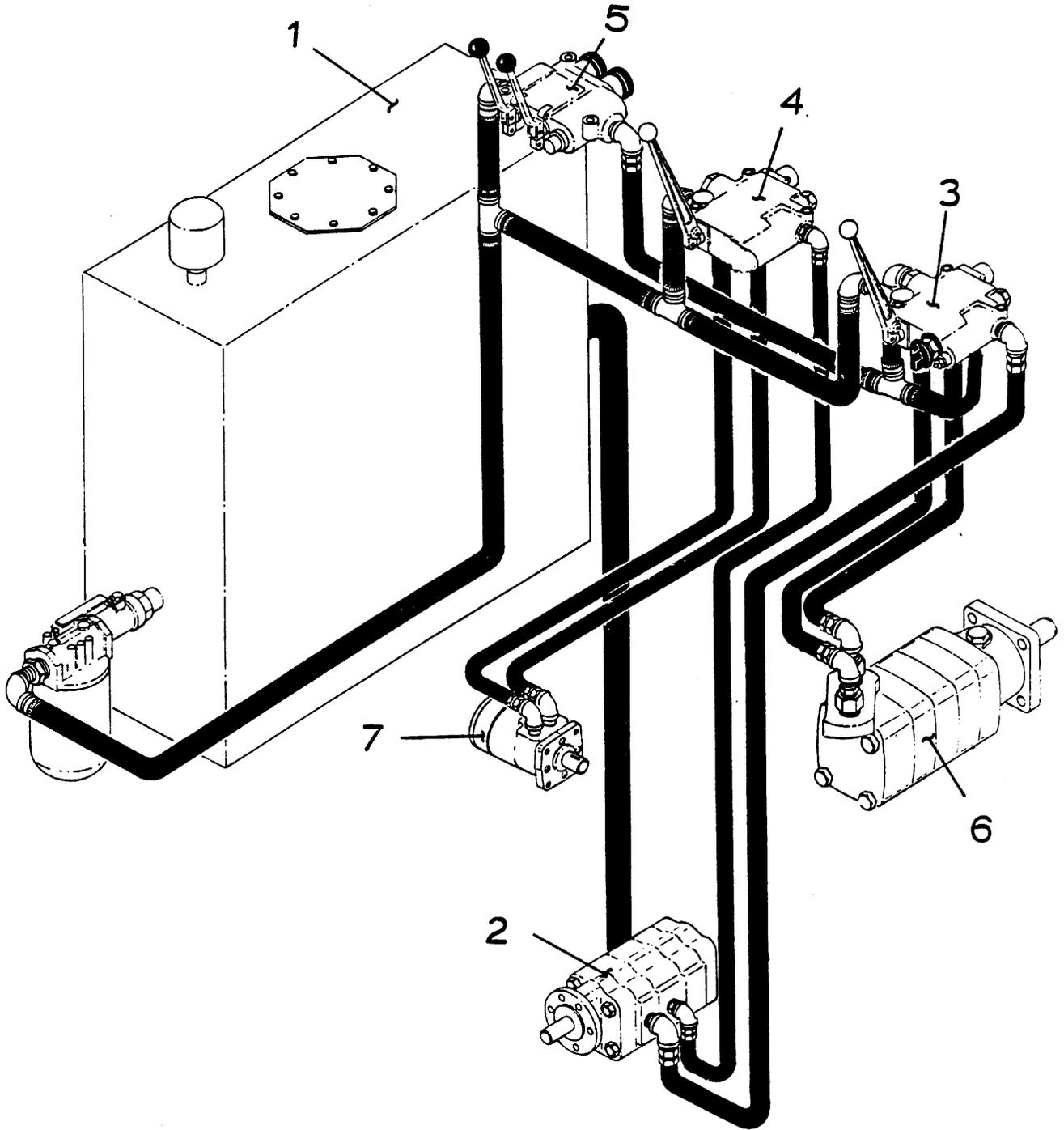

(FIGURE 2)

OPERATION

CONTROLS:

All controls for operation of the debarker are mounted on the operator's platform. (See Figure 3)

Before debarking logs, operator should read operating procedures and check all functions of the debarker. Start motors and operate each function without logs being in debarker. This will help operator to become familiar with operation.

MOTOR STARTING:

Controls for electric motors are located on the starter enclosure to operator's left on the platform. To start motors, turn disconnect handle to "ON" position and push two (2) "START" buttons for hydraulic pump motor and cutter head drive motor.

LOG ADVANCE AND LOADING:

Debarker cutter head must be in the raised or up position before logs are loaded onto debarker. To move logs forward on the deck chains, push the valve lever marked "LIVE DECK" (See Figure Valve #3). Move logs up to stop and loader arms and allow log to roll into arms. Push the same lever which will lower arms and cause log to roll from arms onto bullwheels of debarker.

NOTE: DECK AND STOP AND LOADER VALVE WILL NOT OPERATE IF BULLWHEELS ARE ROTATING. YOU MUST ALWAYS STOP BULLWHEELS BEFORE OPERATING DECK AND STOP AND LOADER.

LOG ROTATION:

Determine desired log rotation. Push or pull handle of valve marked "LOG ROTATION" to position indicated for desired log rotation. (See Figure 3 - Valve #1). This valve has a detent, which allows spool to be locked in either position for log rotation. The speed of rotation can be increased or decreased by turning the knob on this valve.

CARRIAGE TRAVEL:

The valve marked "CARRIAGE TRAVEL" controls the movement of the carriage. (See Figure 3 - Valve #2). Push the handle of the valve to move carriage away from operator and pull the handle to move carriage toward operator. The handle must be held in position for carriage movement. When releasing the handle, a spring will return the handle to the neutral position and will stop the carriage travel.

OPERATION

HEAD OPERATION:

The valve marked "HEAD UP & DOWN" controls the up or down position of the head and also controls the pressure the head exerts on the log. (See Figure 3 - Valve #4).

When debarking logs, move carriage to position head over log. Push valve handle forward to bring head in contact with log. When contact is made, allow valve handle to return to center position. The head will remain in the down position and will "float" over log as carriage is moved over length of log.

If more head pressure is desired on log, push valve handle forward quickly and allow it to return to center position. This action can be repeated until the maximum head pressure is against the log.

For less pressure on the log, pull the handle quickly and allow the handle to return to center position to reduce pressure on log. This may be repeated until head is exerting only minimum pressure on log. To raise the head, pull the valve handle and hold until head is in the raised position.

LOG KICKOFF:

CAUTION: ALWAYS MOVE CARRIAGE BEYOND END OF THE LOG AND TO A POINT WHERE IT WILL NOT BE STRUCK BY LOG BEFORE USING THE LOG KICKOFF.

HEAD MUST BE IN THE UP POSITION BEFORE KICKOFF WILL OPERATE

To operate log kickoff, depress button marked "KICKOFF". (See Figure 3 - #5). Kickoff will cycle completely when button is depressed. After kickoff arms return to lowered position a new log may be loaded into debarker.

(FIGURE 3)

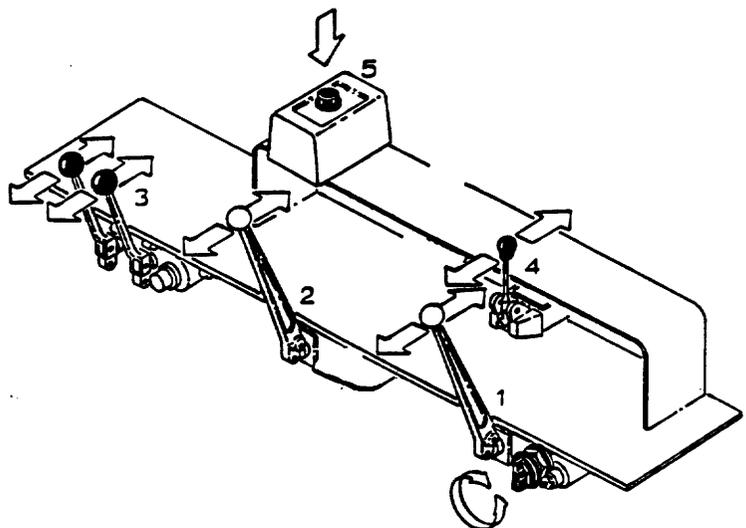

SERVICE

SERVICE AND MAINTENACE SCHEDULE

Every 8 hours

- Lubricate two debarker head bearings
- Lubricate (14) bull wheel shaft bearings
- Lubricate (3) Log Kickoff Shaft Bearings
- Check for loose bolts, worn hoses, etc.
- Check cutter head drive belts
- Drain filter on Filter Regulator-Lubricator by opening valve under bowl

Weekly

- Lubricate (2) counter shaft bearings
- Lubricate All carriage wheels
- Lubricate carriage roller chain and idler sprocket bearings

Yearly

- Lubricate (2) head pivot bearings (pillow block)
- Lubricate (2) head pivot bearing (4- bolt flange)
- Add a small amount of lubricant to electric motor bearings
- Drain oil, remove cartridge filter and internal strainer inside tank and can be cleaned in solvent or diesel fuel and reused
- Replace internal strainer, install new filter cartridge and fill tank to within approximately size inches of top

SERVICE

AIR CIRCUIT SERVICE

1. **FILTER-REGULATOR-LUBRICATOR:** (Located under operator's platform).

- A. **FILTER:** Drain filter by opening valve under bowl. This should be done at the beginning or end of each shift and on a regular basis. The filter can be removed when necessary and washed with mild soap and water.
- B. **REGULATOR:** Pressure setting should be 100 PSI. To increase regulated pressure, turn adjusting handle clockwise. To decrease regulated pressure, turn adjusting handle counter-clockwise. Adjustment can be made either with or without air flowing. When desired setting has been reached, tighten lock nut securely.
- C. **LUBRICATOR:** To fill, remove oil fill plug on top of lubricator, fill to visible rim of bowl with SAE #10 oil (non-detergent motor oil). Replace fill plug and seat firmly. To adjust oil delivery, use a slotted screwdriver to turn the adjusting screw in the top of the lubricator. (Leaner-clockwise/ Richer-counter-clockwise). Monitor flow by looking in the sight dome and count the number of drops per minute. (Six to ten drops per minute should be satisfactory).

CAUTION: CLEAN POLYCARBONATE TRANSPARENT BOWLS WITH MILD SOAP AND WATER ONLY.

CAUTION: SHUT OFF AIR SUPPLY BEFORE DISASSEMBLY OF ANY AIR COMPONENT.

4. **CONTROL VALVES:** Both the hand operated valve mounted on the control valve stand and the solenoid operated valve located on the frame under the operator's platform have spool seals that may need replacement after a period of operation. Sticking valve spools indicate that new seals should be installed. Seal kits are available for these valves.

5. **HEAD CONTROL AIR CYLINDER:** This air cylinder is equipped with cushions which keep the cylinder from banging at the end of its stroke. Adjustment for cushion is small screw located in the cylinder ends. Backing the screw out gives less cushion and turning the screw in gives more cushion.

Seal kits are available for replacement of worn or damaged cylinder seals.

6. **LOG KICKOFF AIR CYLINDER:** This cylinder is equipped with cushions which keep the cylinder from banging at the end of its stroke. Adjustment for cushion is a small screw located in the cylinder ends. Backing the screw out gives less cushion and turning the screw in gives more cushion.

The speed of these cylinders is controlled by the two exhaust restrictors located on the exhaust ports of the solenoid operated air valve. Turning the screw of the restrictor in slows the speed and turning the screw out increases speed. Seal kits are available for replacement of worn or damaged cylinder seals.

SERVICE

HYDRAULIC CIRCUIT SERVICE

1. **HYDRAULIC OIL:** Once a year, drain hydraulic oil from tank and refill with non-foaming hydraulic oil SAE 10. Capacity of the tank is 100 gallons. Tank can be drained by opening the drain hole at bottom of tank. If moisture collects in tank, drain this water off by opening the drain plug. An indication of water in the oil would be white foaming oil.

CAUTION: USE ONLY CLEAN HYDRAULIC OIL- DO NOT PERMIT DIRT TO ENTER TANK OR USE DIRTY CONTAINERS TO HANDLE OIL

2. **INTERNAL SUCTION STRAINER:** Located inside the tank on the suction side should be removed and washed in solvent or diesel fuel when hydraulic oil is changed. Access to this filter is gained by removing the lid from top of tank.

3. **FILTER CARTRIDGE:** Located on the return side of tank should be inspected after first 50 hours of operation and at intervals of 250 hours. Cartridge manufacture recommends replacement at these times.

CAUTION: CLOSE SHUT-OFF VALVE LOCATED NEXT TO CARTIDGE FILTER WHEN REMOVAL AND INSPECTION OF CARTIDGE IS MADE. BE SURE TO OPEN VALVE PRIOR TO STARTING PUMP.

4. **VALVES AND MOTORS:** Make periodical inspection of hydraulic control valves and hydraulic motors to see if any hydraulic oil is leaking at these components. Oil leaks can usually be corrected by installing a new seal kit in the valve or motor.

SERVICE

GEAR COUPLING INSTALLATION: (See FIGURE 4)

1. Remove bolts that hold electric motor to carriage
2. Remove existing coupling

NOTE: GEAR COUPLING MUST BE MOUNTED AS IN FIGURE 4

3. Motor shaft side:
 - A. Insert taper lock hub into sleeve assembly so that taper lock bushing can be inserted in hub from motor shaft.
 - B. Slide 1-7/8" bushing onto motor shaft. Slide taper lock hub and sleeve assembly onto motor shaft until the end of the taper lock hub is flush with the end motor shaft.
 - C. Use set screws to join bushing to taper lock hub.
 - D. 1-1/4" between hub faces will result in proper tooth spacing.

NOTE: RUBBER SEAL IN SLEEVE ASSEMBLY MUST BE SEATED IN GROOVE WHEN HUB IS INSTALLED.

4. Drive shaft side:
 - A. Insert taper lock hub into sleeve assembly so that taper lock bushing can be inserted into hub from end of shaft
 - B. Slide taper lock hub and sleeve assembly onto drive shaft.
 - C. Insert 1-15/16" bushing into hub and tighten with setscrews.
 - D. 1-1/4" between hub faces will result in proper tooth spacing

NOTE: RUBBER SEAL IN SLEEVE ASSEMBLY MUST BE SEATED IN GROOVE WHEN HUB IS INSTALLED

5. Re-position electric motor so that couplings are in line.
6. Install gasket between sleeve assemblies and join sleeve assemblies with cap screws and lock nuts. Gasket and cap screws are packaged in Accessory Kit.
7. Install bolts to fasten electric motor to carriage
8. Install grease fitting into hole provided in the sleeve assembly and lubricate assembly until coupling is full of grease. Then you must remove grease fitting and install original plug.

GEAR COUPLING
(MODEL 210-3)

FIGURE 4

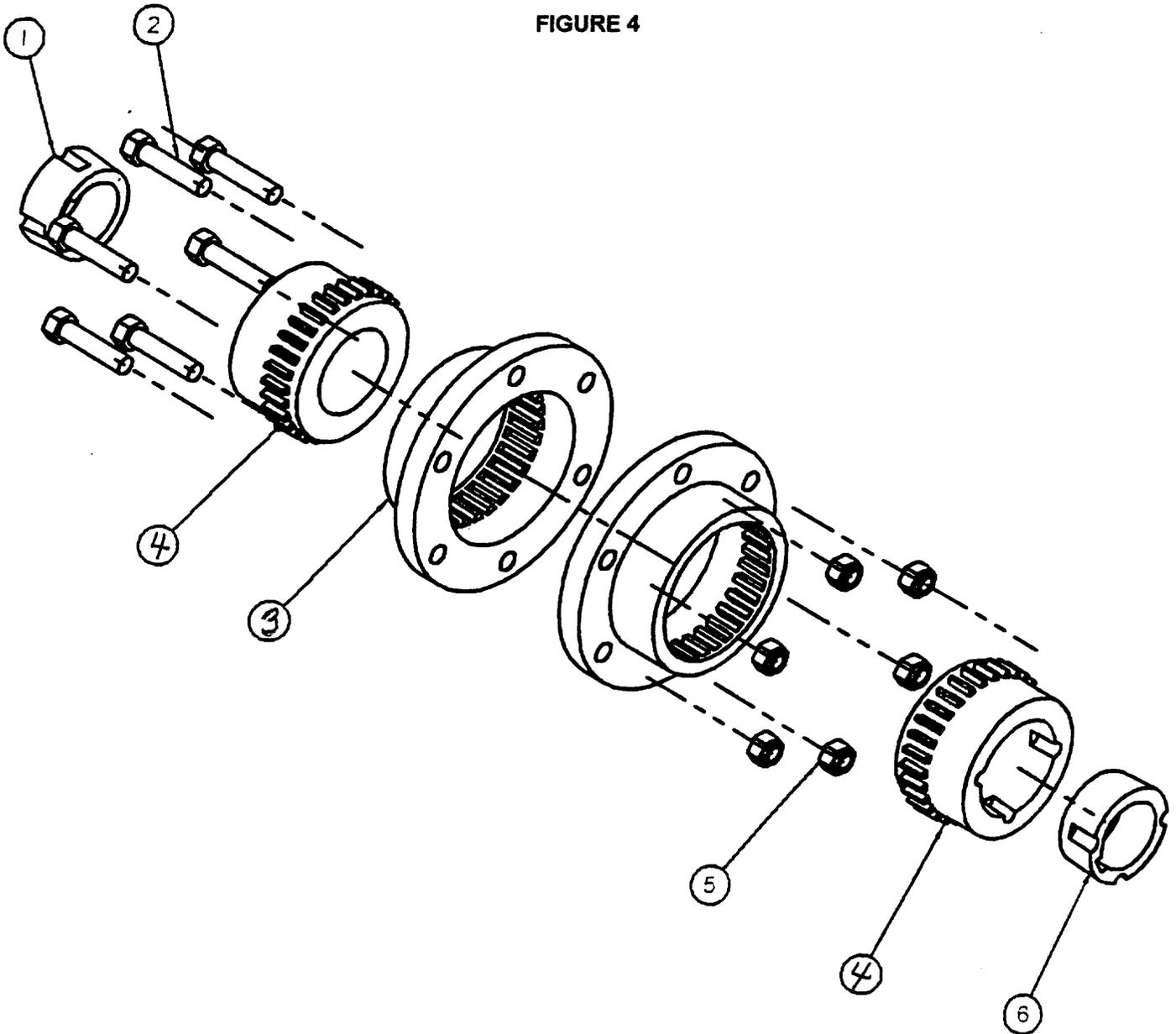

PARTS LIST			
REF. NO.	PART NO.	DESCRIPTION	QTY.
1	2012	BUSHING 1-7/8"	1
2	1/2"-13 X 2-1/4"	HEX HEAD CAP SCREW (149777/2W KIT)	6
3	498127 / 2W	SLEEVE ASSEMBLY	2
4	085020 / 2W	TAPER LOCK HUB	2
5	1/2"-13	NYLON LOCK NUT (149777/2W KIT)	6
6	2012	BUSHING 1-15/16"	1

IMPORTANT: INSTALLING PROXIMITY SWITCHES

When installing proximity switch in cylinders, it is absolutely critical that the switch height be correctly set. Failure to do it correctly will DESTROY the switch and possibly DAMAGE the cylinder.

1. To install switch in base end of cylinder, the cylinder rod must be RETRACTED INTO THE CYLINDER COMPLETELY at the end of its' stroke.
2. Install nylon sealing nut on switch with the nylon insert towards switch.
3. Screw it almost completely to the wiring end of the switch.
4. Install switch in cylinder and screw it in until the sensing end contacts the rod.
5. Back it out one complete turn and hold in that location while locking the nylon sealing nut against the face of the cylinder.
6. The switch is now set.

NOTE: The switch is installed in the rod end the same way except the cylinder rod must be FULLY EXTENDED OUT OF THE CYLINDER when setting the switch height.

SERVICE

HEAD BELT REPLACEMENT

(FOR DEBARKERS EQUIPPED WITH GEAR COUPLINGS)

1. Loosen bolts holding right-hand and left-hand housing shields to head housing. This will allow cutter head to be moved and tension removed from belts.
2. Remove V-belts from sheave on cutter head shaft.
3. Remove V-belt from sheave on right side of carriage.
4. Remove six cap screws holding gear coupling sleeve assemblies.
5. Slide one sleeve assembly toward motor, slide other sleeve assembly toward sheave until there is sufficient gap between sleeve assemblies to remove worn belt.
6. New belts may now be installed.
7.
 - a) Slide gear coupling sleeve assemblies together with gasket in place and install six cap screws with lock nuts.
 - b) Re-lubricate gear coupling by installation of grease fittings into hole provided in sleeve assembly and lubricate assembly until coupling is full of grease.
 - c) Remove grease fitting and install original plug.
8. Adjust housing shields for proper belt tension and tighten bolts
9. Cutter head shaft must be parallel with drive shaft.