

MELLOTT MFG. CO. INC.
 DRAWING NO. 2/16/78
 PART NO. JLP
 VIBRATING CONVEYOR
 TYPE 4

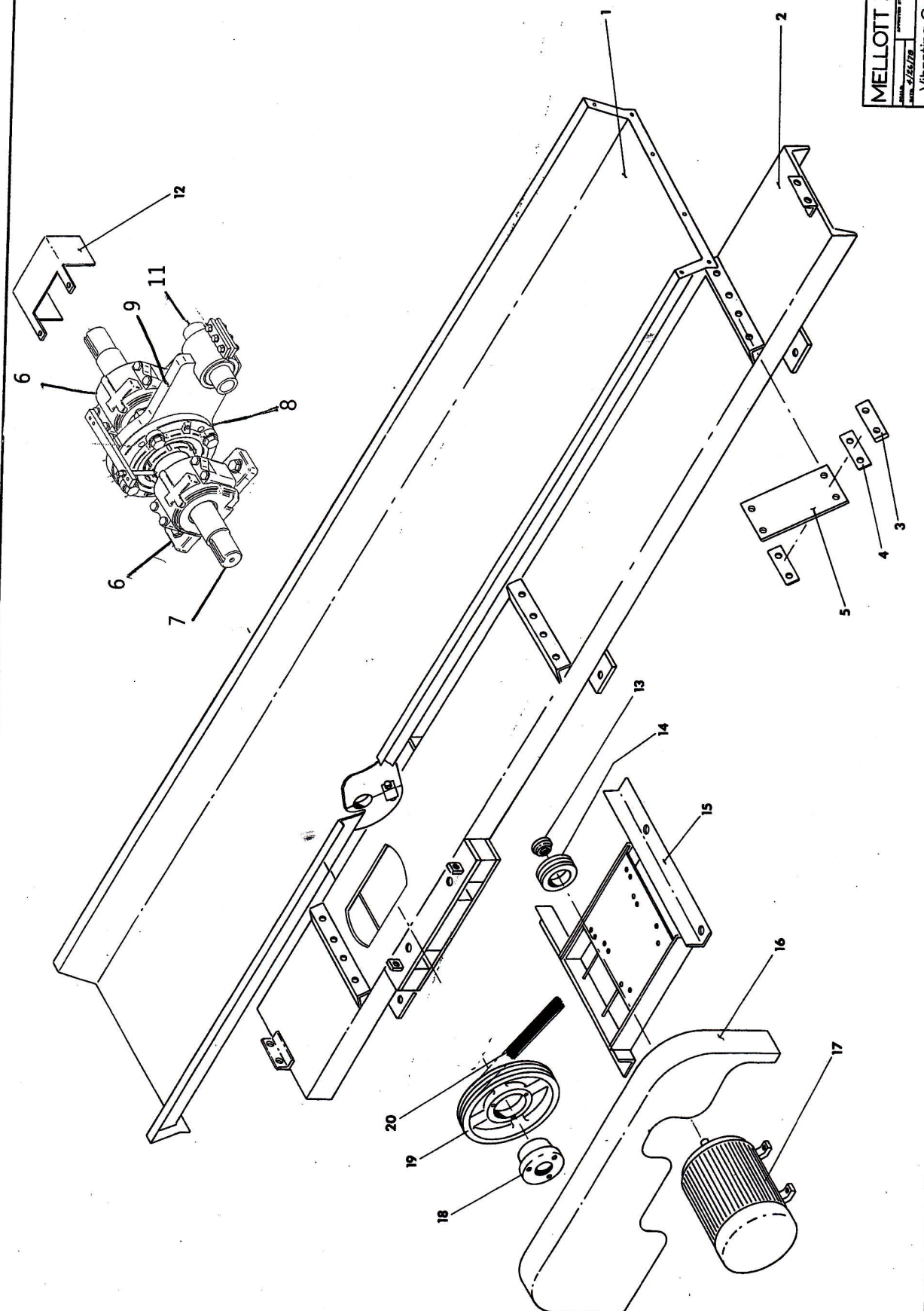

MELLOTT PARTS LIST- VIBRATING CONVEYOR (TYPE 4)

<u>REF. NO.</u>	<u>PART NO.</u> <u>150-3 STD.</u>	<u>PART NO.</u> <u>150-4 HVY.</u>	<u>DESCRIPTION</u>	<u>QTY.</u> <u>REQ.</u>
1	10-150317	10-150417	**PAN WELDMENT, 10' ECC.	1
NS	10-151301	10-151401	**PAN WELDMENT, 10' INT.	1
NS	10-152301	10-152401	**PAN WELDMENT, 75" INT.	1
NS	10-152306	10-150406	**PAN WELDMENT, 60" INT.	1
NS	10-153301	10-153401	**PAN WELDMENT, 45" INT.	1
NS	10-159301	10-153401	PAN WELDMENT, 10' SCEEN	1
2	10-150302	10-150402	BASE WELDMENT, 10' ECC.	1
3	10-150303-1	10-150403-1	BAR KEEPER	6
4	10-150304	10-150404	SPACER	24
5	10-150305 (5" x 12")	10-150405 (5" x 18")	SPRING	6
6	PLB-6835H (2-3/16")	PLB-6839H (2-7/16")	PILLOW BLOCK BEARING	2
7	16-150301	16-150401	SHAFT, ECCENTRIC	1
8	ZBR6215	ZBR6307	PILOTED FLANGE BEARING	1
9	21-180A-059	21-180B-026-S	ECC. WELDMENT ARM	1
11	J6740-3	J6740-3	BUSHING	1
12	10-156303	10-156403	SHIELD	1
13	SH 1-1/8"	SH 1-1/8"	BUSHING	1
14	3/3V x 3.0	3/3V x 3.0	SHEAVE	1
15	10-156401	10-156401	MOTOR BASE ADJ.	1
16	10-156301*	10-156301*	SHIELD, R/H (SHOWN)	1
17	5 H.P. 1800 RPM	5 H.P. 1800 RPM	ELECTRIC MOTOR	1
18	SK 2-3/16"	SK 2-3/16"	BUSHING	1
19	3/3V x 10.6	3/3V x 10.6	SHEAVE	1
20	3/3V x 560	3/3V 560	V-BELT	1

** All Vibrating Conveyors Pans are made with 1/4" Material

*For left hand drive models use L.H. as a number suffix.

For Conveyors with other than 5 H.P. electric motors-See detailed vibrating conveyor drives for replacement parts

MELLOTT MFG. CO., INC.

13156 LONG LANE
MERCERSBUG, PA 17236
TEL: 717-369-3125
FAX: 717-369-2800

www.mellottmfg.com

parts@mellottmfg.com