

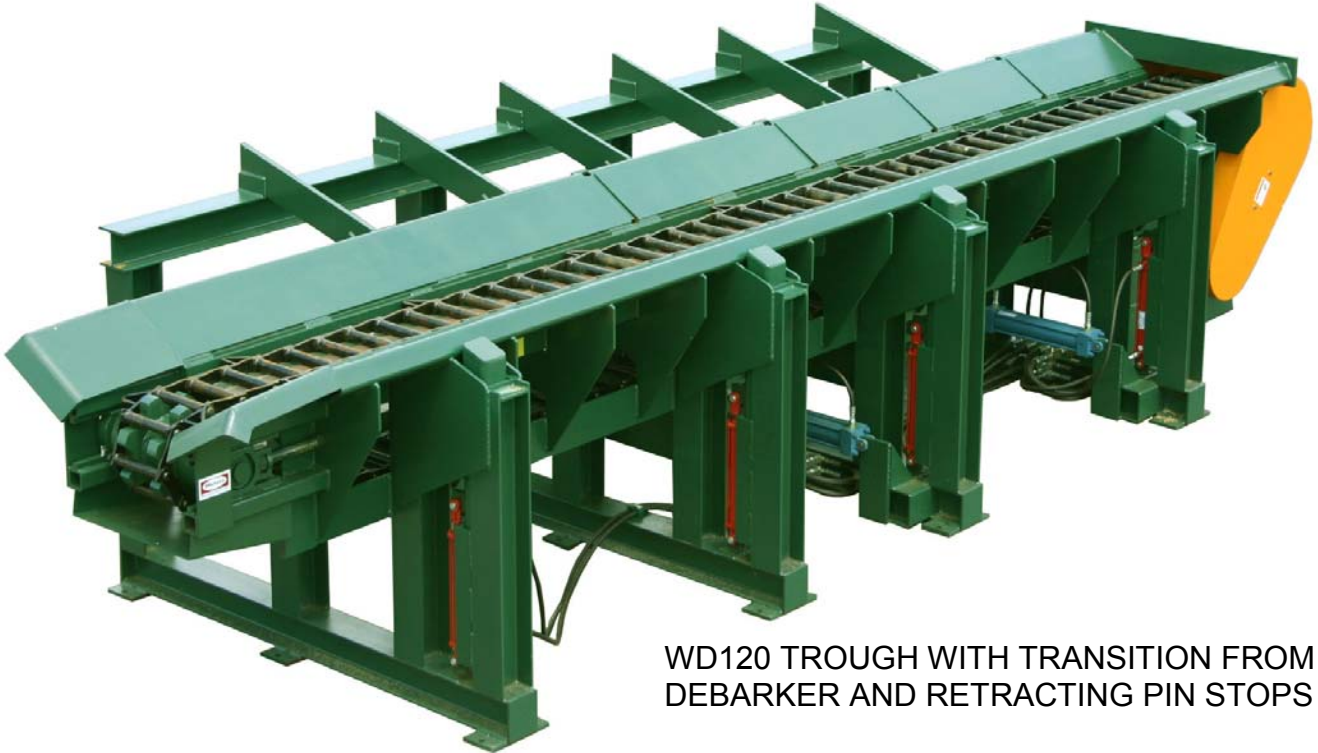

Mellott

LOG AND LUMBER HANDLING EQUIPMENT

WD120 LOG TROUGH



WD120 TROUGH WITH TRANSITION FROM DEBARKER AND RETRACTING PIN STOPS

FEATURES

- The Mellott Log Trough conveyor is designed to move logs lengthwise.
- They can be equipped with kickoffs to the right, left, or both sides.
- The kickers are available with automatic or manual controls.
- The kicker functions can be configured for either air or hydraulic operation.
- Drive options include electric motor with foot mounted speed reducer or a hydraulic motor using a chain drive .
- The log chain is WD120 with wings which travels on AR plate steel (UHMW wear strip optional).
- The conveyor is available in standard lengths of 20' featuring drive, intermediate, and tail sections. Special layouts or design requirements are available.

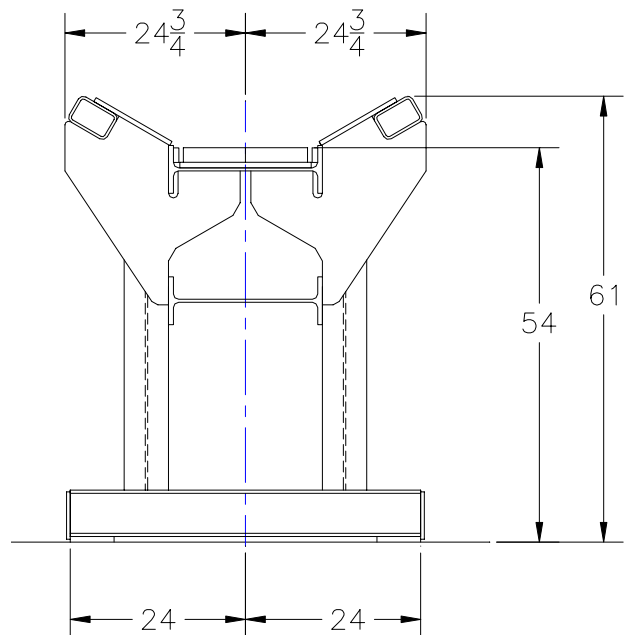

MELLOTT MFG. CO., INC.
13156 Long Lane
Mercersburg, PA 17236

SOLD BY:



LOG AND LUMBER HANDLING EQUIPMENT

WD120 LOG TROUGH

SPECIFICATIONS

Chain	WD120 Round Barrel With Wings
Base Frame.....	W6 x 25 Beam
Chain Way	W21 x 57 Beam With 5/8" A.R. Wear Plate
Trough	5/8" Plate With 1/2" Plate Gussets
Log Diameter.....	54" Maximum
Hydraulic Drive.....	Eaton 10,000 Series Motor with 140 Roller Chain
Electric Drive	Sumitomo Foot Mounted Cyclo Reducer With 15 Hp Motor
Shaft Sizes.....	3-7/16"
Speed.....	115 FPM
Wear Plate	5/8" A.R. Plate Standard, UHMW Optional
Kickoff	4 Arm, 1 1/2" Flame Cut Plates
Air Kickoff.....	(2) 8" x 18" cylinders per kicker
Hydraulic Kickoff.....	(2) 3 1/4" x 18" cylinders per kicker
Hydraulic Log Jack, Log Clamp, Stop On End, Transition And Reinforcement Are Optional	

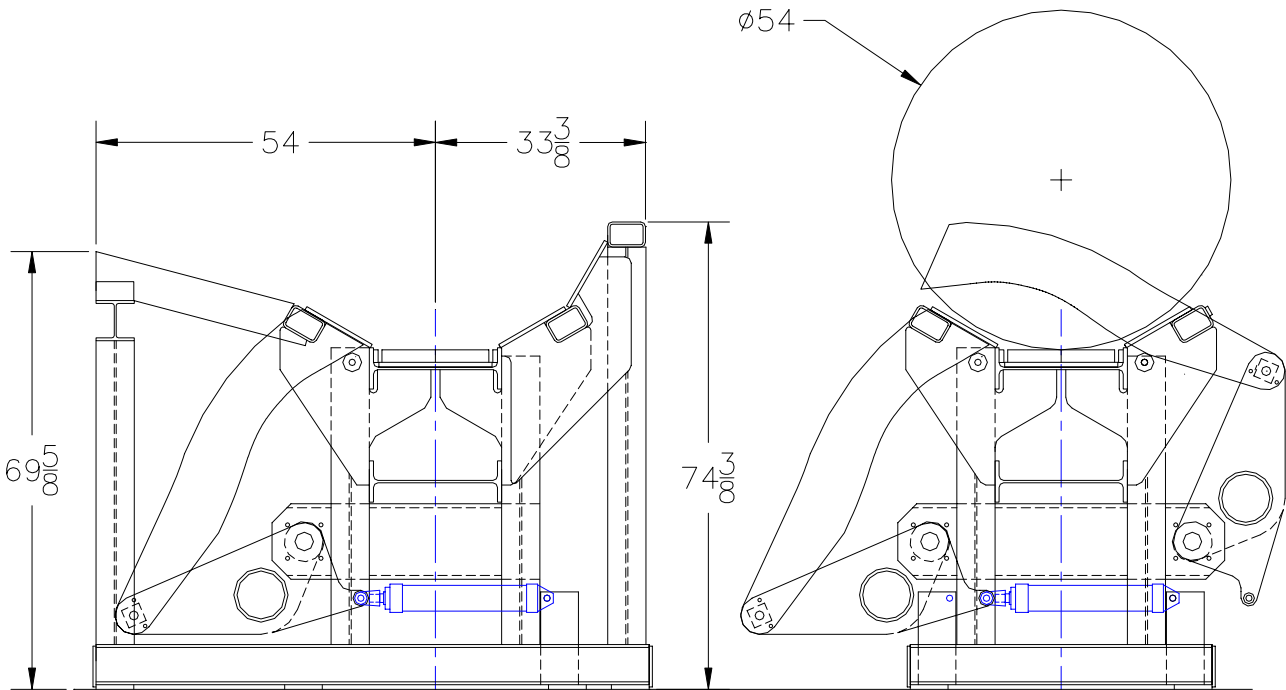

END VIEW WITH TRANSITION FROM DEBARKER AND REINFORCEMENT WITH BACKSTOP

END VIEW WITH DOUBLE KICKOFF

MELLOTT MFG. CO., INC.

13156 Long Lane
Mercersburg, PA 17236

Phone: (717) 369-3125 Fax: (717) 369-2800

SOLD BY: