

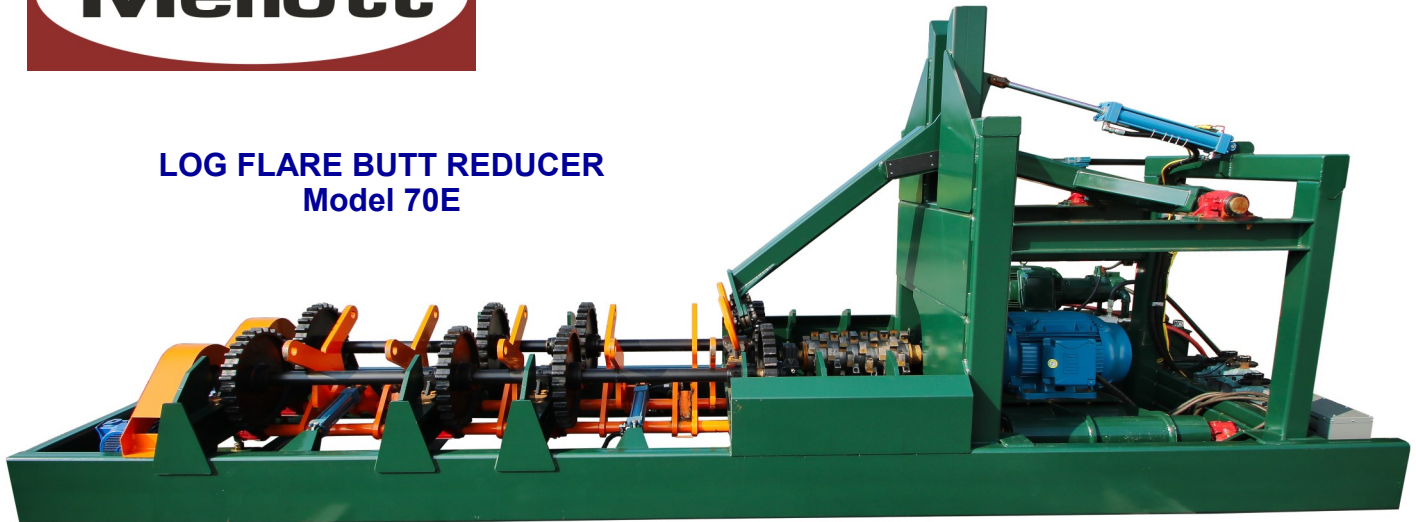

## LOG AND LUMBER HANDLING SYSTEMS

### LOG FLARE BUTT REDUCER Model 70E



Custom designed log flare butt reducer with dual kick out arms

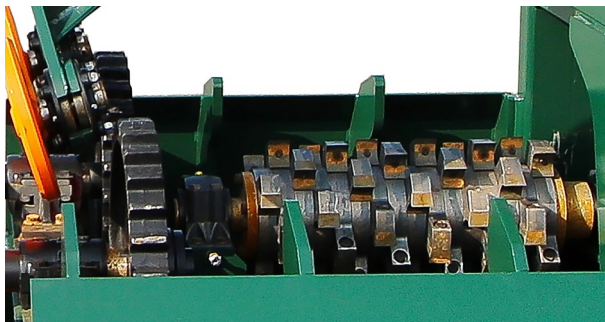

The Mellott cutterhead design is 14" diameter x 28" wide sectional steel with 48 reversible teeth and a 3-15/16" shaft.

The cutterhead is driven by a 100 HP, 1200 RPM, electric motor direct coupled to the drive shaft.

As featured on the Mellott LMR Debarkers, the log butt flare reducer also has solid cast steel alloy bullwheels with Browning HS1 hubs and bushings.

The bullwheel shafts are 3-7/16" diameter with split urethane lined pillow block bearings.

### FEATURES

Mellott Model 70E Log Flare Butt Reducer is designed and built with the same rugged quality as the LMR Debarkers and across all the Mellott product lines. Adding a log flare butt reducer to your mill infeed system will vastly reduce log handling problems and improve productivity.

The Mellott log butt flare reducer standard unit will handle 12" to 48" diameter logs with a maximum flare diameter of 60" and log lengths of 8 ft. up to 17 ft.

The overhead hold down wheels can be operated with hydraulic or pneumatic cylinders.

The bullwheels are driven with a 10 HP Sumitomo helical bevel reducer.

Optional 60 HP hydraulic power source with 45 gpm pressure compensated pump, 200 gallon tank, fully assembled and tested.

The machine has an automatic control system with the option of a wireless remote control.

The log butt flare reducer can be a stand-alone machine or can be supplied with infeed decks or log trough conveyors.

---

#### MELLOTT MFG. CO., INC.

13156 Long Lane  
Mercersburg, PA 17236  
Phone: (717) 369-3125 Fax: (717) 369-2800  
sales@mellottmfg.com  
www.mellottmfg.com

[www.mellottmfg.com](http://www.mellottmfg.com)



# LOG AND LUMBER HANDLING SYSTEMS

## LOG FLARE BUTT REDUCER Model 70E

### SPECIFICATIONS

Log Capacity (Diameter).....	12" to 48" (60" Maximum Flare)
Log Capacity (Length).....	8 ft. up to 17 ft.
Length (Overall).....	25'-7"
Width (Frame).....	68"
Frame Construction.....	3/8" Wall Tubing & 1" Plate
Bull Wheels.....	Cast Alloy Steel
Bull Wheel Drive.....	10 HP Electric Variable Speed
Bull Wheel Shafts.....	3 7/16"
Bull Wheel Shaft Bearings.....	Split Flange With Urethane Sleeves
Log Kick Off.....	Electrically Operated Hydraulic Valve
Log Kick Off Cylinders.....	(2) 2 1/2" x 12" Cylinders
Log Kick Off Shaft.....	2 15/16"
Head.....	14" Diameter, 28" wide
Head Control.....	3 1/4" x 10" Hydraulic Cylinder
Head Bearings.....	3 7/16" Spherical Roller Pillow Block
Head Drive.....	100 HP 1200 RPM Motor
Hydraulic Pump Motor.....	60 HP Motor
Hydraulic Tank Capacity.....	200 Gallon
Motor Controls.....	Included
Wiring.....	480 3 phase w/120 controls
Operators Controls.....	Remote Control, Included
Overall Weight.....	Approximately 26,500 Lbs.

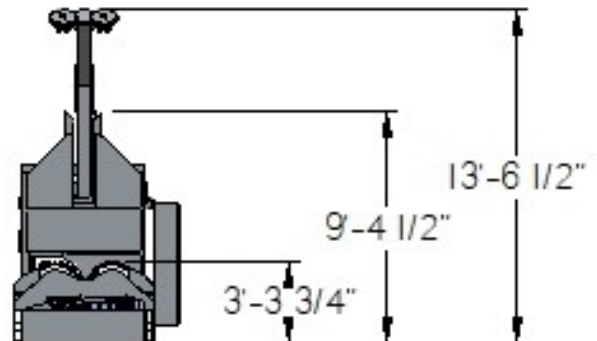
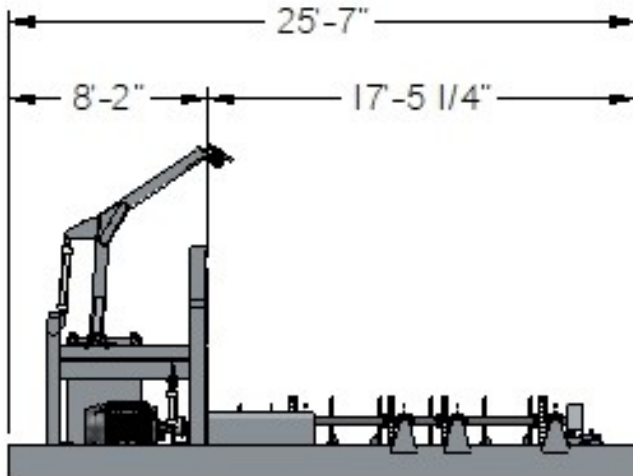
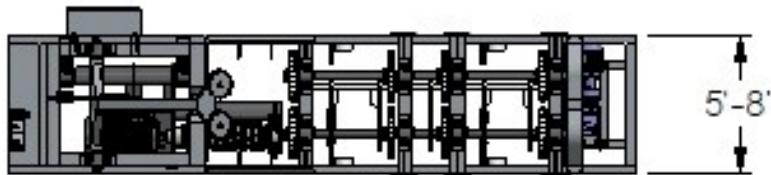

### MELLOTT MFG. CO., INC.

13156 Long Lane  
 Mercersburg, PA 17236  
 Phone: (717) 369-3125 Fax: (717) 369-2800

[www.mellottmfg.com](http://www.mellottmfg.com)