

WR132 LOG TROUGH

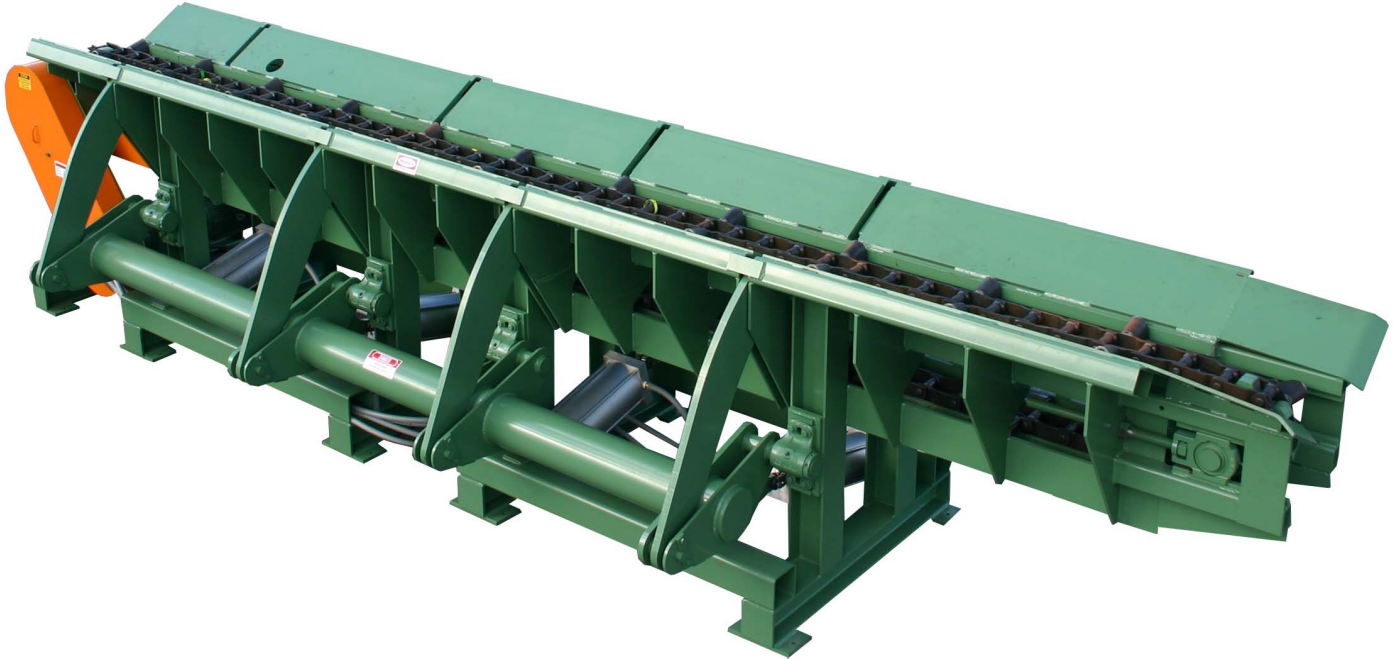

WR132 LOG TROUGH WITH DOUBLE KICKOFF AND DRIVE

FEATURES

- The Mellott Log Trough conveyor is designed to move logs lengthwise.
- They can be equipped with kickoffs to the right, left, or both sides.
- The kickers are available with automatic or manual controls.
- The kicker functions can be configured for either air or hydraulic operation.
- Drive options include electric motor with foot mounted speed reducer or a hydraulic motor using a chain drive .
- The log chain is WR132 with cradles which travels on AR plate steel (UHMW wear strip optional).
- The conveyor is available in standard lengths of 20' featuring drive, intermediate, and tail sections. Special layouts or design requirements are available.
- The Mellott WR132 Log Trough is heavily constructed, designed for decades of service

MELLOTT MFG. CO., INC.

13156 Long Lane
Mercersburg, PA 17236
sales@mellottmfg.com

www.mellottmfg.com



LOG AND LUMBER HANDLING SYSTEMS

WR132 LOG TROUGH

SPECIFICATIONS

Chain	WR132 With Log Cradles
Base Frame.....	W6 x 25 Beam
Chain Way	W16 x 57 Beam With 1/2" A.R. Wear Plate
Trough	5/8" plate trough sides With 1/2" Plate Gussets
Log Diameter.....	42" Maximum
Hydraulic Drive.....	Eaton 10,000 Series Motor with 140 Roller Chain
Electric Drive	Sumitomo Foot Mounted Cyclo Reducer With 15 Hp Motor
Shaft Sizes.....	3-7/16"
Speed.....	115 FPM
Wear Plate	1/2" A.R. Plate Standard, UHMW Optional
Kickoff	4 Arm, 1 1/4" Flame Cut Plates
Air Kickoff.....	(2) 8" x 18" cylinders per kicker
Hydraulic Kickoff.....	(1) 3 1/4" x 18" cylinders per kicker
Hydraulic Log Jack, Log Clamp, Stop On End, Transition And Reinforcement Are Optional	

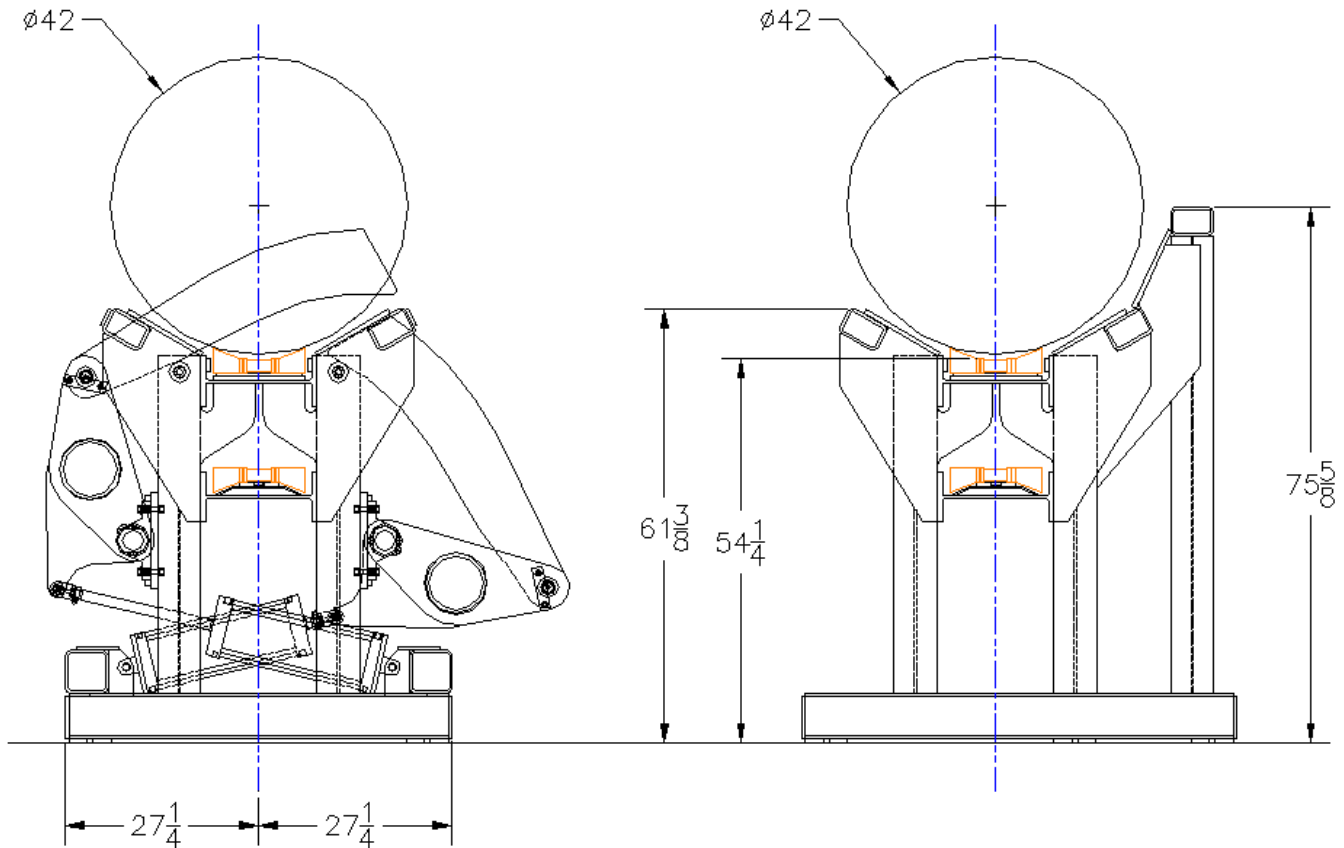

MELLOTT MFG. CO., INC.

13156 Long Lane
 Mercersburg, PA 17236
 Phone: (717) 369-3125 Fax: (717) 369-2800
 sales@mellottmfg.com

www.mellottmfg.com